

1. The Lathe

1.1 Introduction

Lathe is considered as one of the oldest machine tools and is widely used in industries. It is called as mother of machine tools. It is said that the first screw cutting lathe was developed by an Englishman named Henry Maudslay in the year 1797. Modern high speed, heavy duty lathes are developed based on this machine.

The primary task of a lathe is to generate cylindrical workpieces. The process of machining a workpiece to the required shape and size by moving the cutting tool either parallel or perpendicular to the axis of rotation of the workpiece is known as turning. In this process, excess unwanted metal is removed. The machine tool useful in performing plain turning, taper turning, thread cutting, chamfering and knurling by adopting the above method is known as lathe.

1.2 Main parts of a lathe

Every individual part performs an important task in a lathe. Some important parts of a lathe are listed below:

1. Bed
2. Headstock
3. Spindle
4. Tailstock
5. Carriage
 - a. Saddle
 - b. Apron
 - c. Cross-slide
 - d. Compound rest
 - e. Compound slide
 - f. Tool post
6. Feed mechanism
7. Lead screw
8. Feed rod

1.2.1 Bed

Bed is mounted on the legs of the lathe which are bolted to the floor. It forms the base of the machine. It is made of cast iron and its top surface is machined accurately and precisely. Headstock of the lathe is located at the extreme left of the bed and the tailstock at the right extreme. Carriage is positioned in between the headstock and tailstock and slides on the bed guide ways.

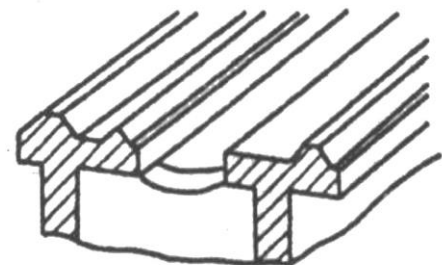

Fig 1 : Lathe bed with V shaped guideway

The top of the bed has flat or ‘V’ shaped guide ways. The tailstock and the carriage slides on these guide ways. Inverted ‘V’ shaped guide ways are useful in better guide and accurate alignment of saddle and tailstock. The metal burrs resulting from turning operation automatically fall through. Flat bed guide ways can be found in older machine tools. It is useful in heavy machines handling large workpieces. But then the accuracy is not high.

1.2.2 Headstock

Headstock is mounted permanently on the inner guide ways at the left hand side of the leg bed. The headstock houses a hollow spindle and the mechanism for driving the spindle at multiple speeds. The headstock will have any of the following arrangements for driving and altering the spindle speeds:

- (i) Stepped cone pulley drive
- (ii) Back gear drive
- (iii) All gear drive

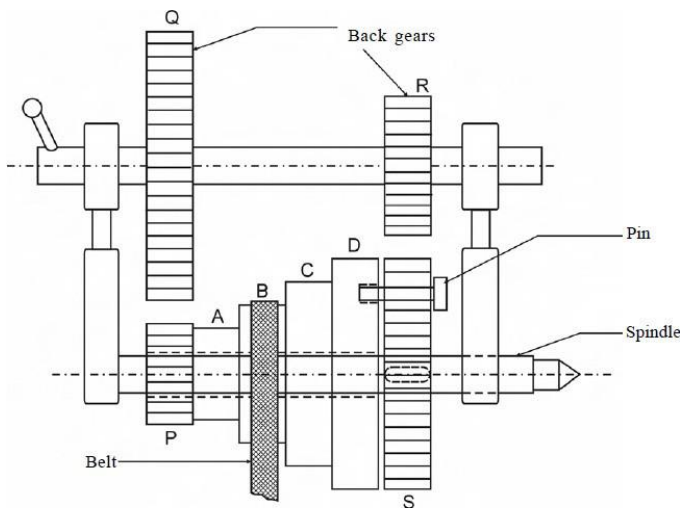

Fig 2: Stepped cone pulley with back gear

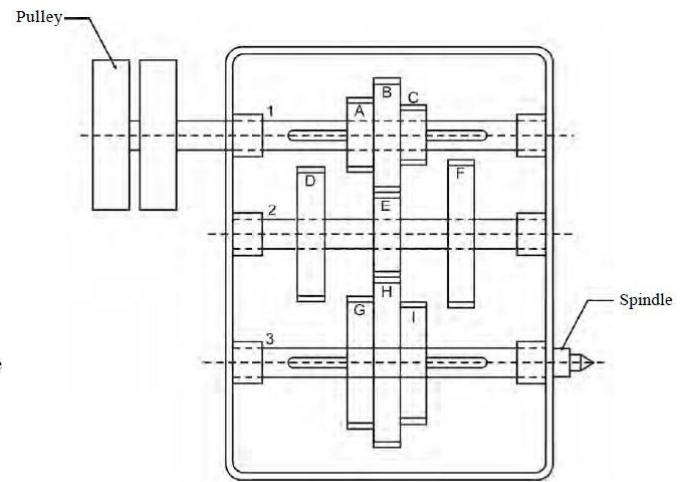

Fig 3: All gear drive

1.2.3 Spindle

The spindle rotates on two large bearings housed on the headstock casting. A hole extends through the spindle so that a long bar stock may be passed through the hole. The front end of the spindle is threaded on which chucks, faceplate, driving plate and catch plate are screwed. The front end of the hole is tapered to receive live centre which supports the work. On the other side of the spindle, a gear known as a spindle gear is fitted. Through this gear, tumbler gears and a main gear train, the power is transmitted to the gear on the leadscrew.

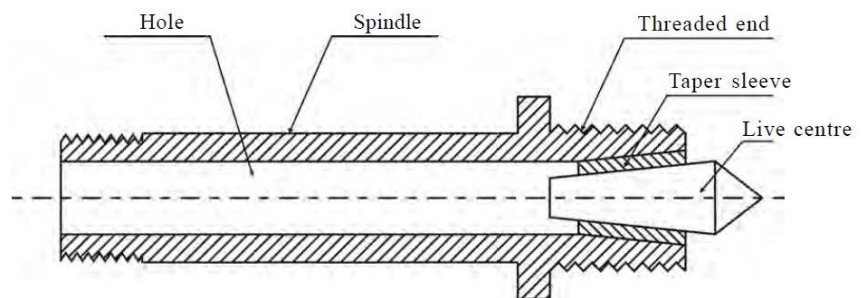

Fig 4: Head stock spindle

1.2.4 Tailstock

Tailstock is located on the inner guide ways at the right side of the bed opposite to the headstock. The body of the tailstock is bored and houses the tailstock spindle. The spindle moves front and back inside the hole. The spindle has a taper hole to receive the dead centre or shanks of tools like drill or reamer. If the tailstock hand wheel is rotated in the clockwise direction, the spindle advances. The spindle will be withdrawn inside the hole, if the hand wheel is rotated in anti-clockwise direction.

The main uses of tailstock are:

1. It supports the other end of the long workpiece when it is machined between centres.

2. It is useful in holding tools like drills, reamers and taps when performing drilling, reaming and tapping.

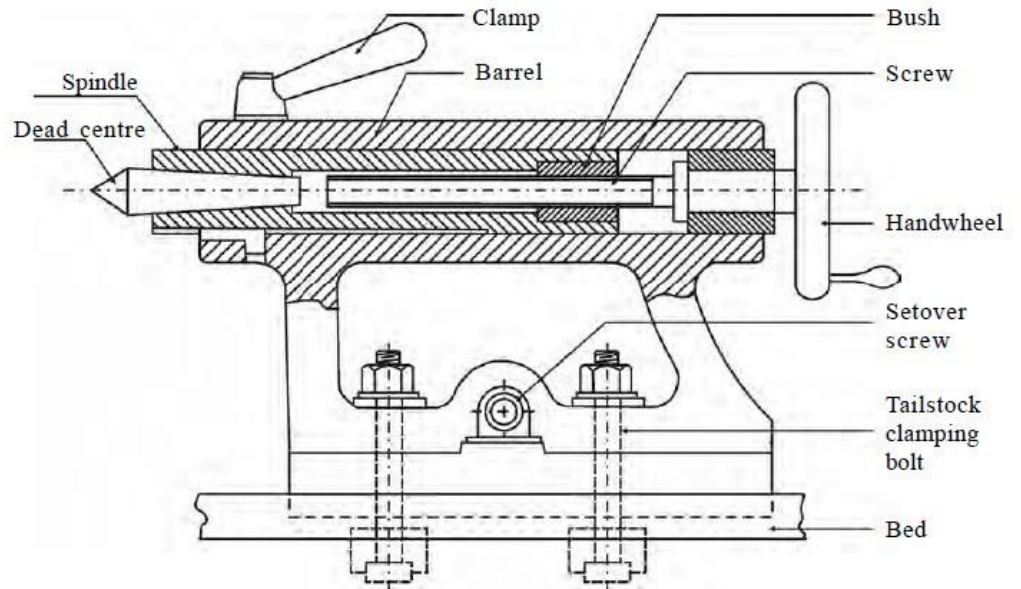

Fig 5: Tail stock

1.2.5 Carriage

Carriage is located between the headstock and tailstock on the lathe bed guide ways. It can be moved along the bed either towards or away from the headstock. It has several parts to support, move and control the cutting tool. The parts of the carriage are:

- a) saddle
- b) apron
- c) cross-slide
- d) compound rest
- e) compound slide
- f) tool post

Saddle:

It is an “H” shaped casting. It connects the pair of bed guide ways like a bridge. It fits over the bed and slides along the bed between headstock and tailstock. The saddle or the entire carriage can be moved by providing hand feed or automatic feed.

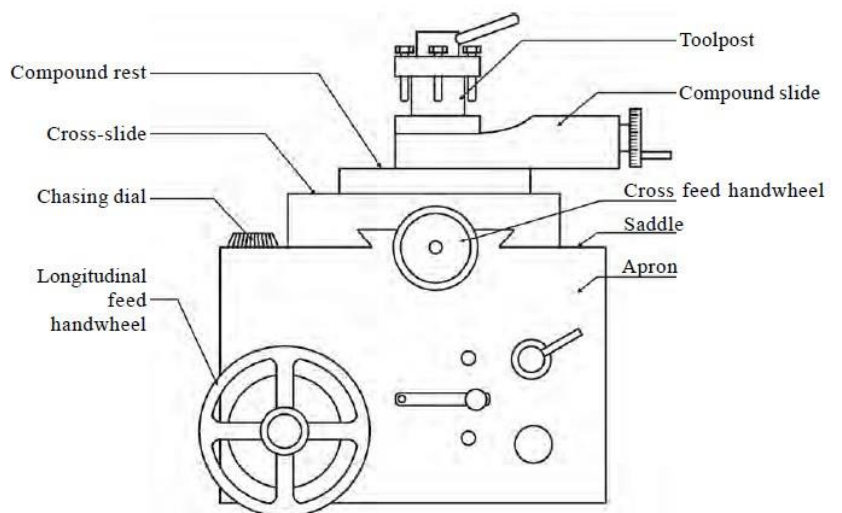

Fig 6: Carriage

Cross slide:

Cross-slide is situated on the saddle and slides on the dovetail guide ways at right angles to the bed guide ways. It carries compound rest, compound slide and tool post. Cross slide hand wheel is rotated to move it at right angles to the lathe axis. It can also be power driven. The cross slide hand wheel is graduated on its rim to enable to give known amount of feed as accurate as 0.05mm.

Compound rest:

Compound rest is a part which connects cross slide and compound slide. It is mounted on the cross-slide by tongue and groove joint. It has a circular base on which angular graduations are marked. The compound rest can be swivelled to the required angle while turning tapers. A top slide known as compound slide is attached to the compound rest by dove tail joint. The tool post is situated on the compound slide.

Tool post:

This is located on top of the compound slide. It is used to hold the tools rigidly. Tools are selected according to the type of operation and mounted on the tool post and adjusted to a convenient working position. There are different types of tool posts and they are:

1. Single way tool post
3. Four way tool post
4. Quick change tool post

Single way tool post

The tool is held by a screw in this tool post. It consists of a round bar with a slotted hole in the centre for fixing the tool by means of a setscrew. A concave ring and a convex rocker are used to set the height of the tool point at the right position. The tool fits on the flat top surface of the rocker. The tool post is not rigid enough for heavy works as only one clamping screw is used to clamp the tool.

Four way tool post

This type of tool post can accommodate four tools at a time on the four open sides of the post. The tools are held in position by separate screws and a locking bolt is located at the centre. The required tool may be set for machining by swivelling the tool post. Machining can be completed in a shorter time because the required tools are pre-set.

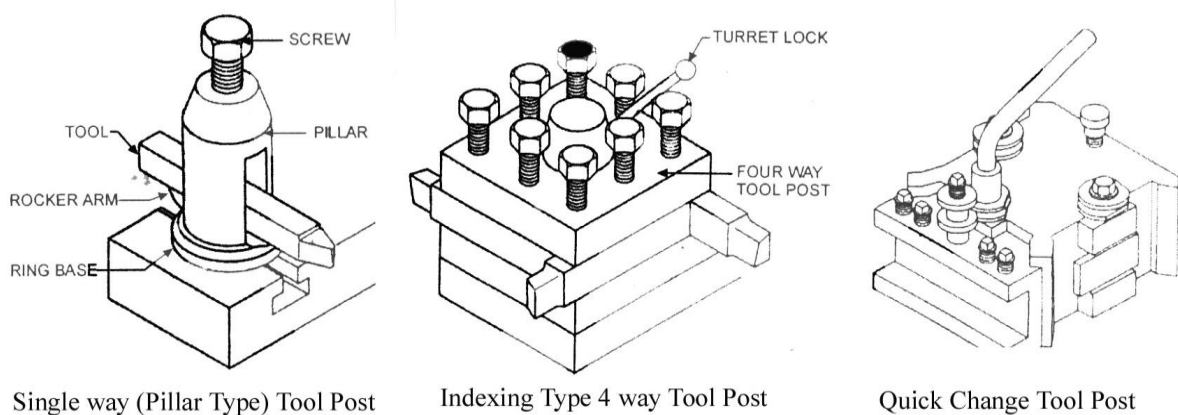

Fig 6: Types of tool posts

1.2.6 Lead screw

The leadscrew is a long threaded shaft used as master screw. It is brought into operation during thread cutting to move the carriage to a calculated distance. Mostly leadscrew are Acme threaded.

The leadscrew is held by two bearings on the face of the bed. A gear is attached to the lead screw and it is called as gear on leadscrew. A half nut lever is provided in the apron to engage half nuts with the leadscrew.

1.2.7 Feed rod

Feed rod is placed parallel to the leadscrew on the front side of the bed. It is a long shaft which has a keyway along its length. The power is transmitted from the spindle to the feed rod through tumbler gears and a gear train. It is useful in providing feed movement to the carriage except for thread cutting and to move cross-slide. A worm mounted on the feed rod enables the power feed movements.

1.3 Types of lathe

Various designs and constructions of lathe have been developed to suit different machining conditions and usage. The following are the different types of lathe:

1. Speed lathe
 - a. Woodworking lathe
 - b. Centering lathe
 - c. Polishing lathe
 - d. Metal spinning lathe
2. Engine lathe
 - a. Belt driven lathe
 - b. Individual motor driven lathe
 - c. Gear head lathe
3. Bench lathe
 - a. Tool room lathe
 - b. Semi automatic lathe
 - c. Capstan lathe
 - d. Turret lathe
4. Automatic lathe
 - a. Wheel lathe
 - b. Gap bed lathe
 - c. 'T' lathe
 - d. Duplicating lathe
5. Special purpose lathe
 - a. Wheel lathe
 - b. Gap bed lathe
 - c. 'T' lathe
 - d. Duplicating lathe

1.4 Size of a lathe (Specification of Lathe)

The size of a lathe is specified by the following points

1. The length of the bed
2. Maximum distance between live and dead centres.
3. The height of centres from the bed
4. The swing diameter:

The swing diameter over bed - It refers to the largest diameter of the work that will be rotated without touching the bed

The swing diameter over carriage - It is the largest diameter of the work that will revolve over the saddle.

5. The bore diameter of the spindle
6. The width of the bed
7. The type of the bed
8. Pitch value of the lead screw
9. Horse power of the motor
10. Number and range of spindle speeds
11. Number of feeds
12. Spindle nose diameter
13. Floor space required
14. The type of the machine

1.5 Work holding devices used in a lathe (accessories)

The work holding devices are used to hold and rotate the workpieces along with the spindle. Different work holding devices are used according to the shape, length, diameter and weight of the workpiece and the location of turning on the work.

They are:

1. Chucks
2. Face plate
3. Driving plate
4. Catch plate
5. Carriers
6. Mandrels
7. Centres
8. Rests

1.5.1 Chucks

Workpieces of short length, large diameter and irregular shapes, which can not be mounted between centres, are held quickly and rigidly in chuck. There are different types of chucks namely, Three jaw universal chuck, Four jaw independent chuck, Magnetic chuck, Collet chuck and Combination chuck.

Three jaw self-Centering chuck

The three jaws fitted in the three slots may be made to slide at the same time by an equal amount by rotating any one of the three pinions by a chuck key. This type of chuck is suitable for holding and rotating regular shaped workpieces like round or hexagonal rods about the axis of the lathe. Workpieces of irregular shapes cannot be held by this chuck. The work is held quickly and easily as the three jaws move at the same time.

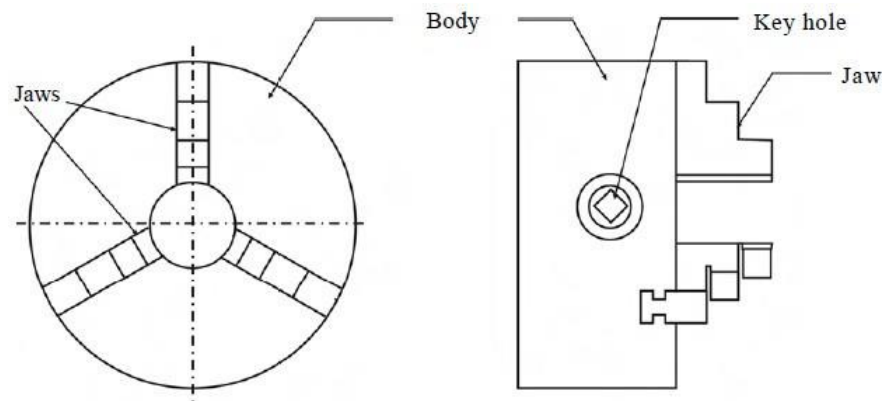

Four jaw independent chuck

There are four jaws in this chuck. Each jaw is moved independently by rotating a screw with the help of a chuck key. A particular jaw may be moved according to the shape of the work. Hence this type of chuck can hold works of irregular shapes. But it requires more time to set the work aligned with the lathe axis. Experienced turners can set the work about the axis quickly. Concentric circles are inscribed on the face of the chuck to enable quick Centering of the workpiece.

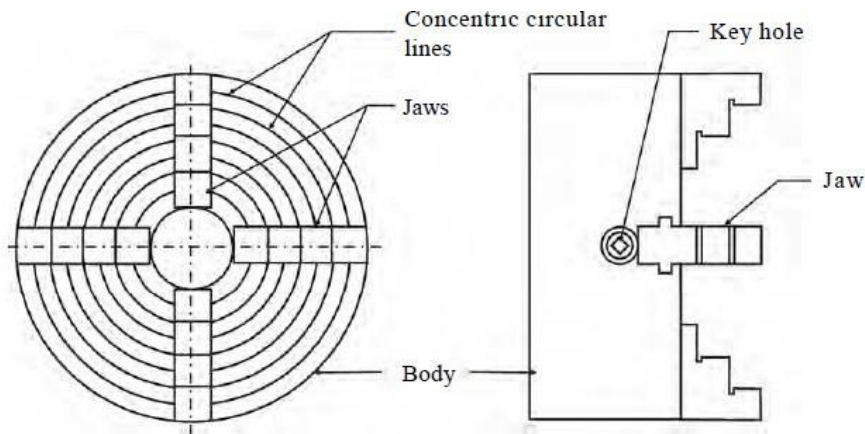

Magnetic chuck

The holding power of this chuck is obtained by the magnetic flux radiating from the electromagnet placed inside the chuck. Magnets are adjusted inside the chuck to hold or release the work. Workpieces made of magnetic material only are held in this chuck. Very small, thin and light works which can not be held in an ordinary chuck are held in this chuck.

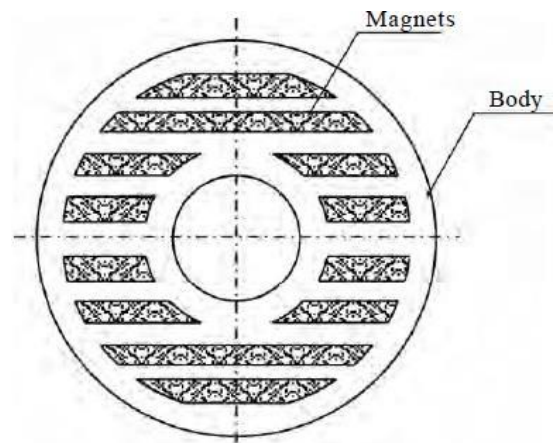

Collet chuck

Collet chuck has a cylindrical bushing known as collet. It is made of spring steel and has slots cut lengthwise on its circumference. So, it holds the work with more grips. Collet chucks are used in capstan lathes and automatic lathes for holding bar stock in production work.

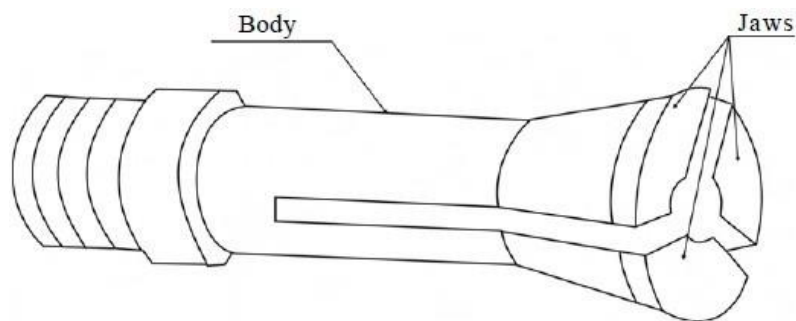

1.5.2 Face plate

Faceplate is used to hold large, heavy and irregular shaped workpieces which can not be conveniently held between centres. It is a circular disc bored out and threaded to fit to the nose of the lathe spindle. It is provided with radial plain and 'T' – slots for holding the work by bolts and clamps.

1.5.3 Driving plate

The driving plate is used to drive a workpiece when it is held between centres. It is a circular disc screwed to the nose of the lathe spindle. It is provided with small bolts or pins on its face. Workpieces fitted inside straight tail carriers are held and rotated by driving plates.

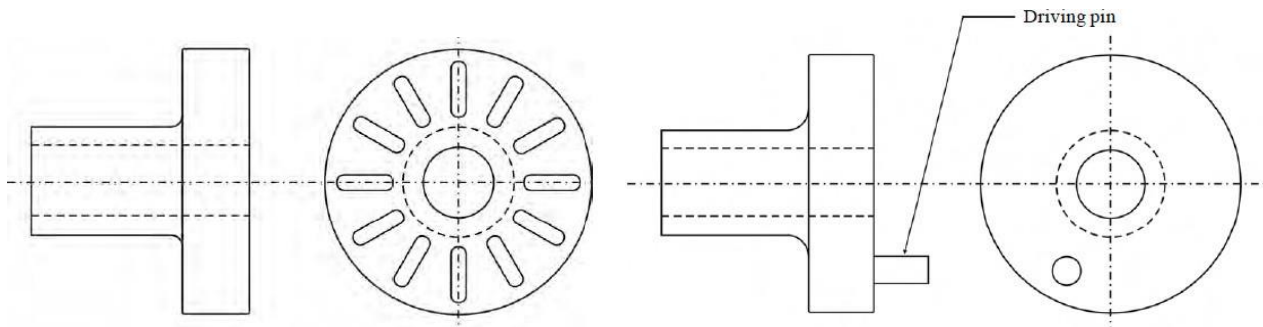

Fig: Face plate

Fig: Driving plate

1.5.4 Catch plate

When a workpiece is held between centres, the catch plate is used to drive it. It is a circular disc bored and threaded at the centre. Catch plates are designed with 'U' – slots or elliptical slots to receive the bent tail of the carrier. Positive drive between the lathe spindle and the workpiece is affected when the workpiece fitted with the carrier fits into the slot of the catch plate.

1.5.5 Carrier

When a workpiece is held and machined between centres, carriers are useful in transmitting the driving force of the spindle to the work by means of driving plates and catch plates. The work is held inside the eye of the carrier and tightened by a screw. Carriers are of two types and they are:

1. Straight tail carrier
2. Bent tail carrier

Straight tail carrier is used to drive the work by means of the pin provided in the driving plate. The tail of the bent tail carrier fits into the slot of the catch plate to drive the work.

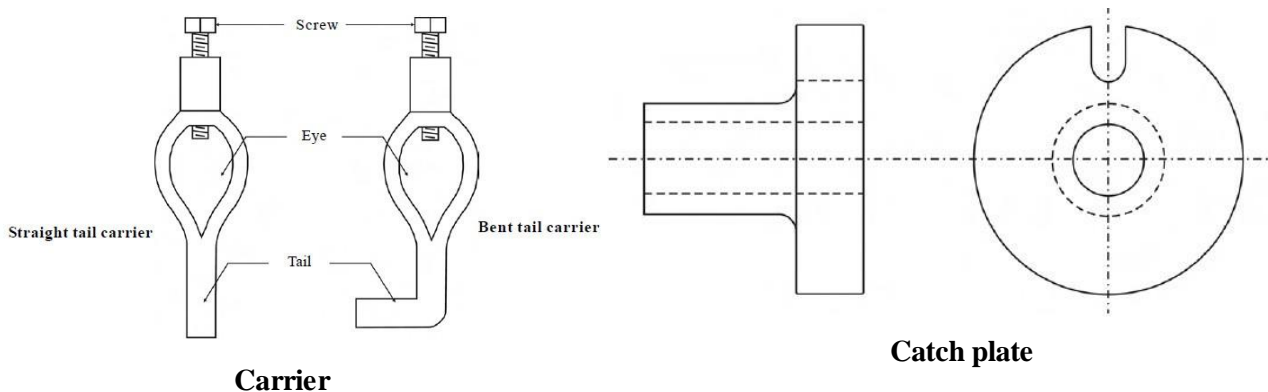

Carrier

Catch plate

1.5.6 Mandrel

A previously drilled or bored workpiece is held on a mandrel to be driven in a lathe and machined. There are centre holes provided on both faces of the mandrel. The live centre and the dead centre fit into the centre holes. A carrier is attached at the left side of the mandrel. The mandrel gets the drive either through a catch plate or a driving plate. The workpiece rotates along with the mandrel.

There are several types of mandrels and they are:

1. Plain mandrel
2. Step mandrel
3. Gang mandrel
4. Collar mandrel
5. Cone mandrel
6. Expansion mandrel
7. Expansion mandrel

Plain mandrel

The body of the plain mandrel is slightly tapered to provide proper gripping of the workpiece. The taper will be around 1 to 2mm for a length of 100mm. It is also known as solid mandrel. It is the type mostly commonly used and has wide application.

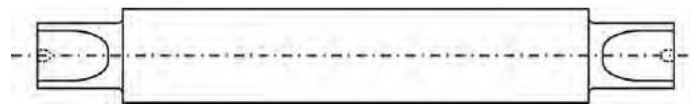

Gang mandrel

It has a fixed collar at one end and a movable collar at the threaded end. This mandrel is used to hold a set of hollow workpieces between the two collars by tightening the nut.

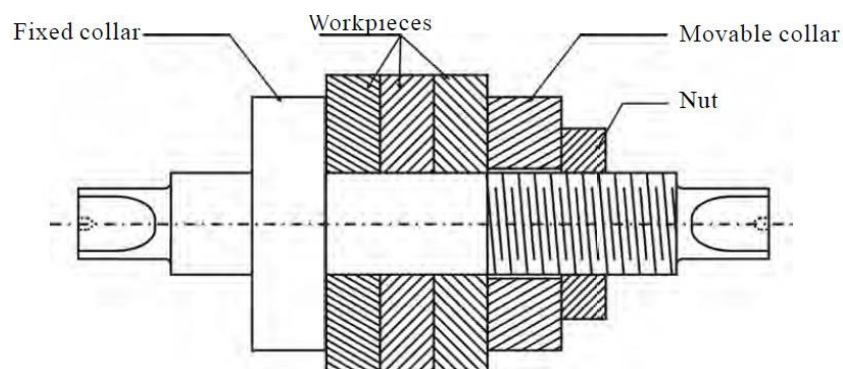

Screwed mandrel

It is threaded at one end and a collar is attached to it. Workpieces having internal threads are screwed on to it against the collar for machining.

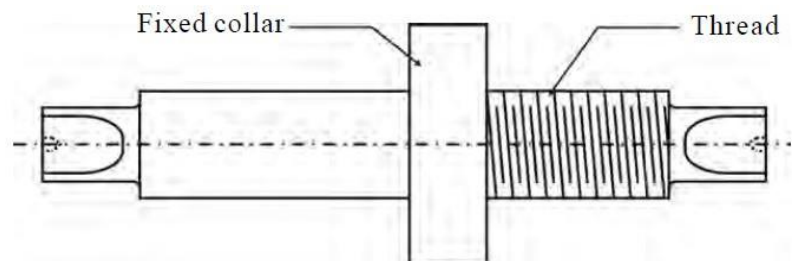

Cone mandrel

It consists of a solid cone attached to one end of the body and a sliding cone, which can be adjusted by turning a nut at the threaded end. This type is suitable for driving workpieces having different hole diameters.

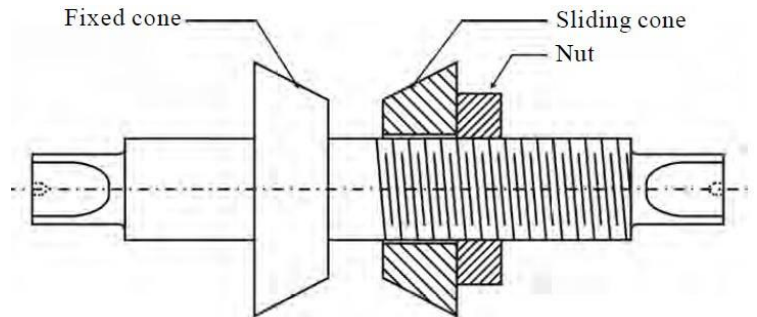

1.5.7 Centres

Centres are useful in holding the work in a lathe between centres. The shank of a centre has Morse taper on it and the face is conical in shape. There are two types of centres namely

- (i) Live centre
- (ii) Dead centre

The live centre is fitted on the headstock spindle and rotates with the work. The centre fitted on the tailstock spindle is called dead centre. It is useful in supporting the other end of the work. Centres are made of high carbon steel and hardened and then tempered. So the tip of the centres are wear resistant.

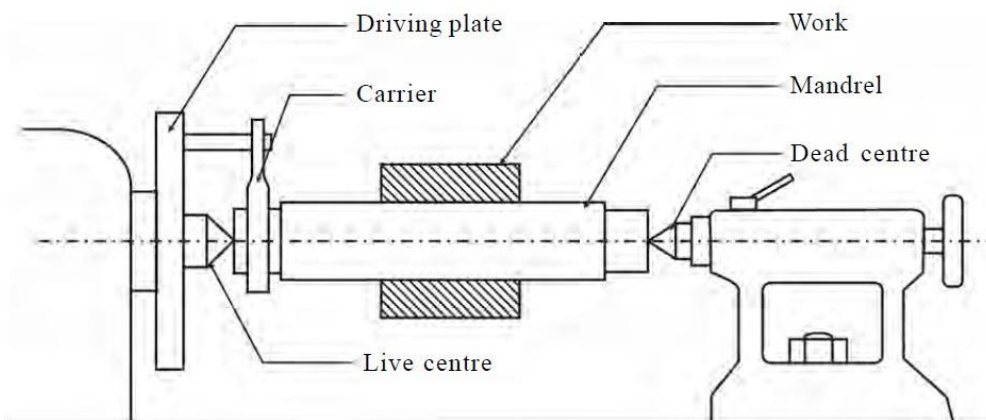

Fig 1.27 Holding a work between centres

Different types of centres are available according to the shape of the work and the operation to be performed. They are:

1. Ordinary centre
2. Ball centre
3. Half centre
4. Tipped centre
5. Pipe centre
6. Revolving centre
7. Inserted type centre

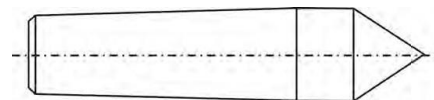

Fig : Ordinary centre

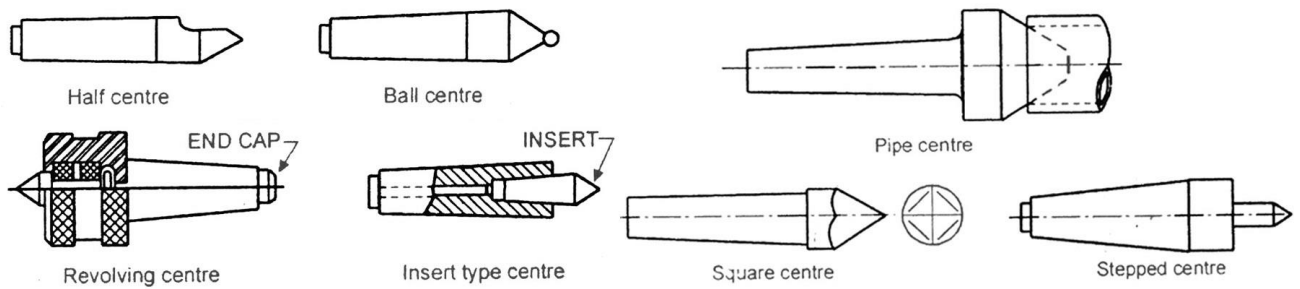

Fig: Types of centres

1.5.8 Rests

A rest is a mechanical device to support a long slender workpiece when it is turned between centres or by a chuck. It is placed at some intermediate point to prevent the workpiece from bending due to its own weight and vibrations setup due to the cutting force.

There are two different types of rests

1. Steady rest
2. Follower rest

Steady rest

Steady rest is made of cast iron. It may be made to slide on the lathe bed ways and clamped at any desired position where the workpiece needs support. It has three jaws. These jaws can be adjusted according to the diameter of the work. Machining is done upon the distance starting from the headstock to the point of support of the rest. One or more steady rests may be used to support the free end of a long work.

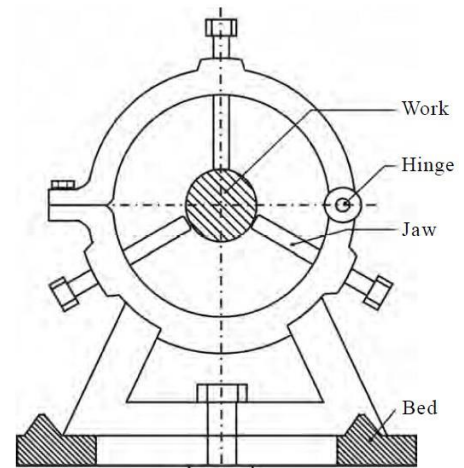

Follower rest

It consists of a 'C' like casting having two adjustable jaws to support the workpiece. The rest is bolted to the back end of the carriage. During machining, it supports the work and moves with the carriage. So, it follows the tool to give continuous support to the work to be able to machine along the entire length of the work. In order to reduce friction between the work and the jaws, proper lubricant should be used.

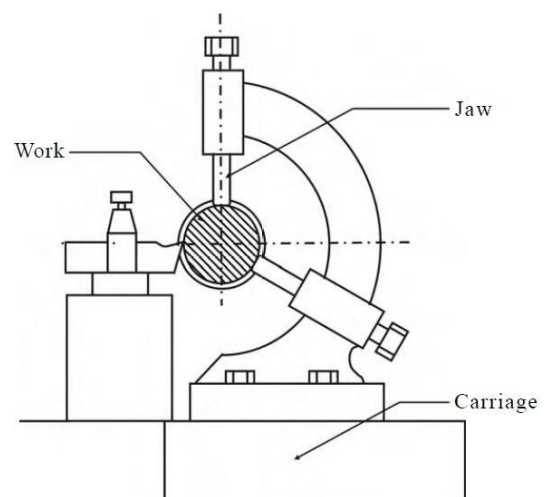

1.6 Operations performed in a lathe

Various operations are performed in a lathe other than plain turning. They are:

1. Facing
2. Turning
 - a. Straight turning
 - b. Step turning
3. Chamfering
4. Grooving
5. Forming
6. Knurling
7. Undercutting
8. Eccentric turning
9. Taper turning
10. Thread cutting
11. Drilling
12. Reaming
13. Boring
14. Tapping

1.6.1 Facing

Facing is the operation of machining the ends of a piece of work to produce flat surface which is square with the axis. The operation involves feeding the tool perpendicular to the axis of rotation of the work.

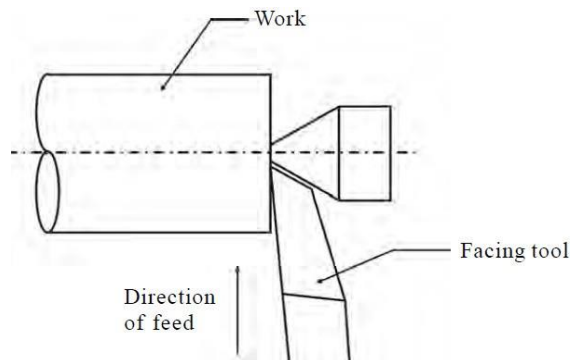

Fig 1.31 Facing

1.6.2 Turning

Turning in a lathe is to remove excess material from the workpiece to produce a cylindrical surface of required shape and size.

Straight turning

The work is turned straight when it is made to rotate about the lathe axis and the tool is fed parallel to the lathe axis. The straight turning produces a cylindrical surface by removing excess metal from the workpieces.

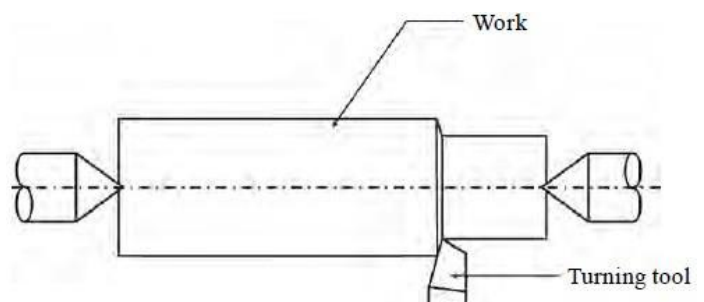

Fig 1.32 Straight turning

Step turning

Step turning is the process of turning different surfaces having different diameters. The work is held between centres and the tool is moved parallel to the axis of the lathe. It is also called shoulder turning.

1.6.3 Chamfering

Chamfering is the operation of bevelling the extreme end of the workpiece. The form tool used for taper turning may be used for this purpose. Chamfering is an essential operation after thread cutting so that the nut may pass freely on the threaded workpiece.

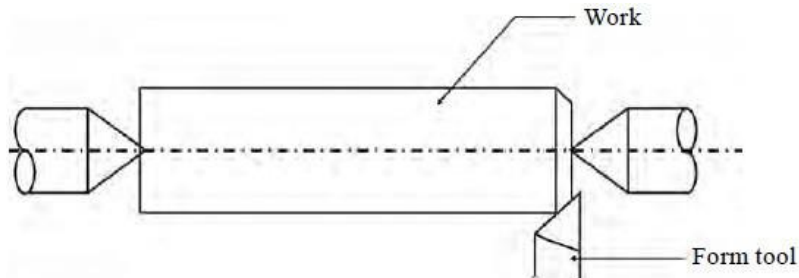
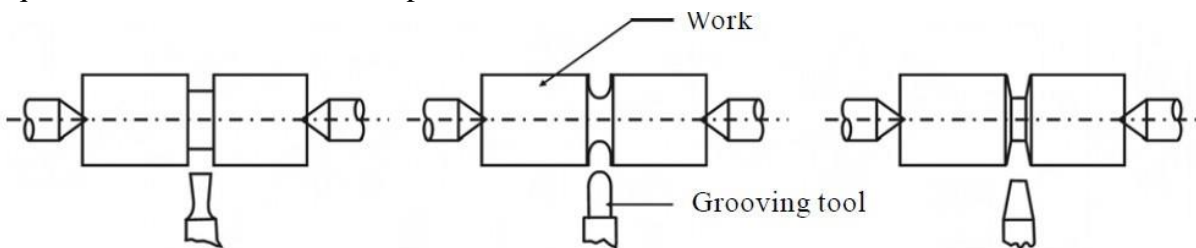

Fig 1.33 Chamfering

1.6.4 Grooving

Grooving is the process of cutting a narrow groove on the cylindrical surface of the workpiece. It is often done at end of a thread or adjacent to a shoulder to leave a small margin. The groove may be square, radial or bevelled in shape.



1.6.5 Forming

Forming is a process of turning a convex, concave or any irregular shape. For turning a small length formed surface, a forming tool having cutting edges conforming to the shape required is fed straight into the work.

1.6.6 Knurling

Knurling is the process of embossing a diamond shaped pattern on the surface of the workpiece. The knurling tool holder has one or two hardened steel rollers with edges of required pattern. The tool holder is pressed against the rotating work. The rollers emboss the required pattern. The tool holder is fed automatically to the required length. Knurls are available in coarse, medium and fine pitches. The patterns may be straight, inclined or diamond shaped.

The purpose of knurling is

1. To provide an effective gripping surface
2. To provide better appearance to the work
3. To slightly increase the diameter of the work

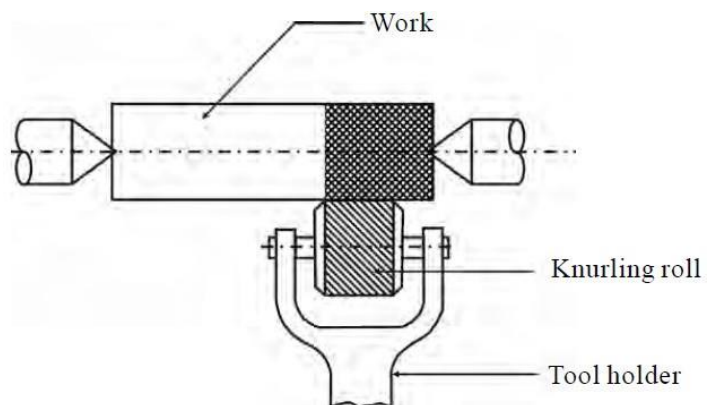

1.6.7 Undercutting

Undercutting is done (i) at the end of a hole (ii) near the shoulder of stepped cylindrical surfaces (iii) at the end of the threaded portion in bolts. It is a process of enlarging the diameter if done internally and reducing the diameter if done externally over a short length. It is useful mainly to make fits perfect. Boring tools and parting tools are used for this operation.

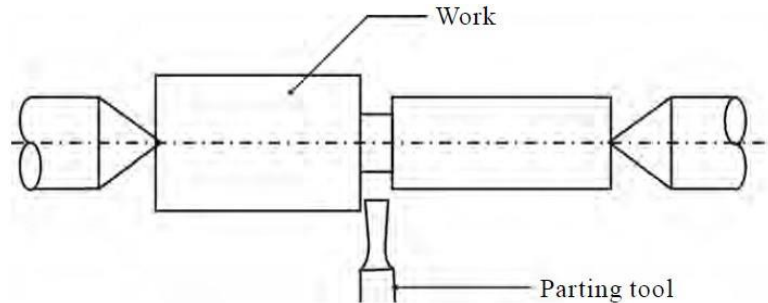

1.6.8 Taper turning

Taper

A taper may be defined as a uniform increase or decrease in diameter of a piece of work measured along its length.

Taper turning methods

1. Form tool method
2. Compound rest method
3. Tailstock set over method
4. Taper turning attachment method
5. Combined feed method

(i) Form tool method

A broad nose tool is ground to the required length and angle. It is set on the work by providing feed to the cross-slide. When the tool is fed into the work at right angles to the lathe axis, a tapered surface is generated. This method is limited to turn short lengths of taper only. The length of the taper is shorter than the length of the cutting edge. Less feed is given as the entire cutting edge will be in contact with the work.

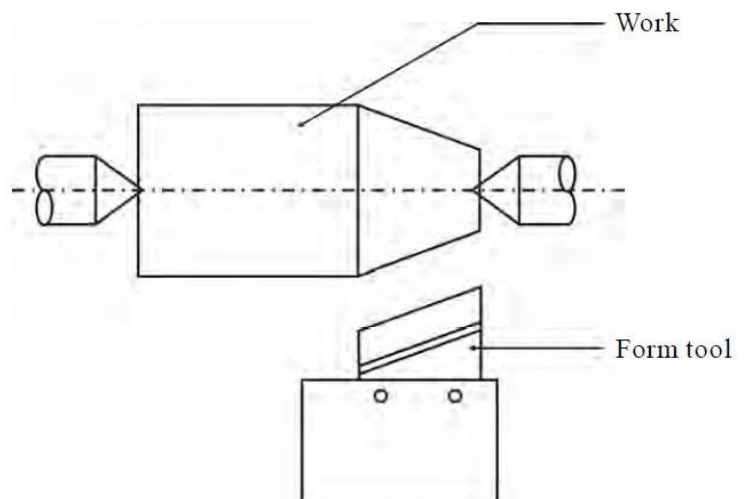

(ii) Compound rest method

The compound rest of the lathe is attached to a circular base graduated in degrees, which may be swivelled and clamped at any desired angle. The angle of taper is calculated using the formula:

$$\tan\theta = \frac{D - d}{2l}$$

where D = Larger diameter

d = Smaller diameter

l = Length of the taper

θ = Half taper angle

The compound rest is swivelled to the angle calculated as above and clamped. Feed is given to the compound slide to generate the required taper.

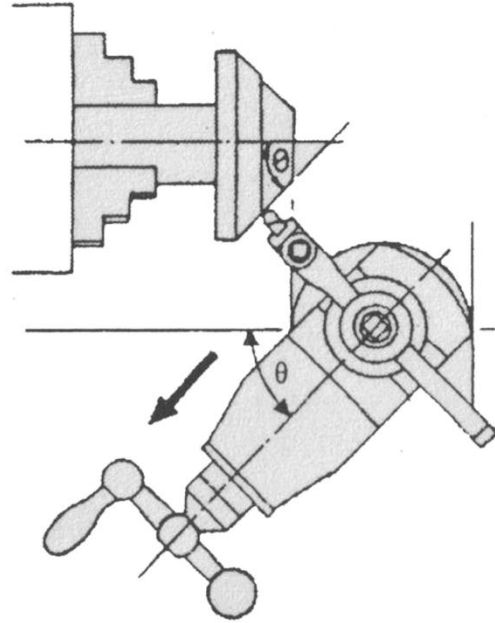

Taper turning by swivelling the compound rest

(iii) Tailstock set over method

Turning taper by the set over method is done by shifting the axis of rotation of the workpiece at an angle to the lathe axis and feeding the tool parallel to the lathe axis. The construction of tailstock is designed to have two parts namely the base and the body. The base is fitted on the bed guide ways and the body having the dead centre can be moved at cross to shift the lathe axis.

The amount of set over (s) can be calculated as follows:

$$\text{setover, } s = L * \frac{D - d}{2l}$$

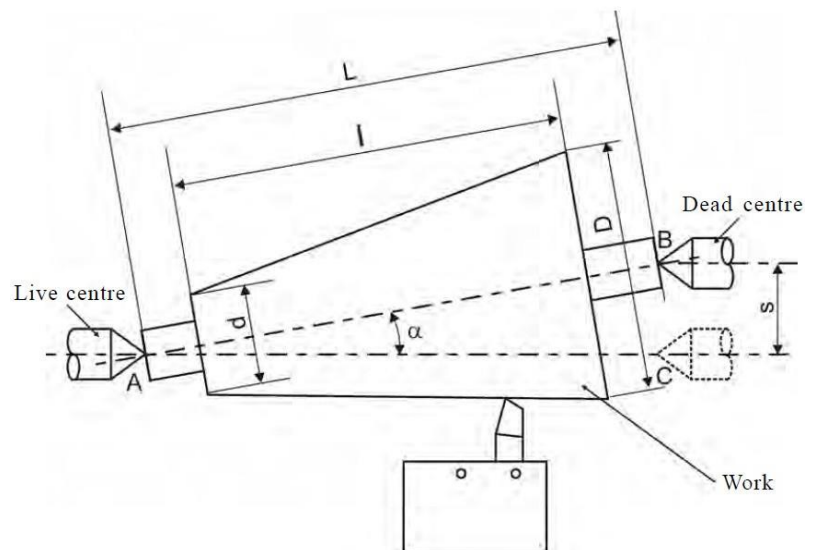

The dead centre is suitably shifted from its original position to the calculated distance. The work is held between centres and longitudinal feed is given by the carriage to generate the taper. The advantage of this method is that the taper can be turned to the entire length of the work. Taper threads can also be cut by this method. The amount of set over being limited, this method is suitable for turning small tapers (approx. upto 8°). Internal tapers cannot be done by this method.

(iv) Taper turning by an attachment

The taper attachment consists of a bracket which is attached to the rear end of the lathe bed. It supports a guide bar pivoted at the centre. The bar having graduation in degrees may be swivelled on either side of the zero graduation and set at the desired angle to the lathe axis. A guide block is mounted on the guide bar and slides on it. The cross slide is made free from its screw by removing the binder screw. The rear end of the cross slide is tightened with the guide block by means of a bolt. When the longitudinal feed is engaged, the tool mounted on the cross slide will follow the angular path as the guide block will slide on the guide bar set at an angle of the lathe axis. The depth of cut is provided by the compound slide which is set parallel to the cross-slide. The advantage of this method is that long tapers can be machined. As power feed can be employed, the work is completed at a shorter time. The disadvantage of this method is that internal tapers cannot be machined.

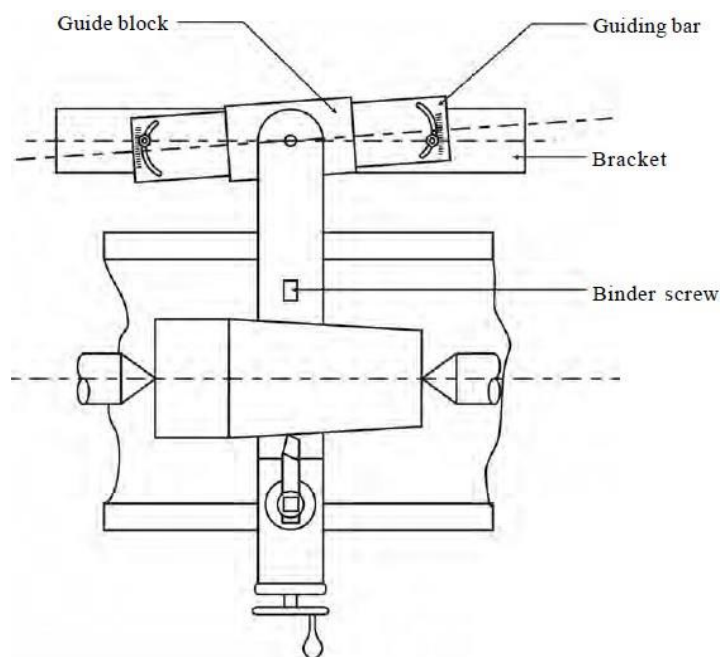

1.6.9 Thread cutting

Thread cutting is one of the most important operations performed in a lathe. The process of thread cutting is to produce a helical groove on a cylindrical surface by feeding the tool longitudinally. The job is revolved between centres or by a chuck. The longitudinal feed should be equal to the pitch of the thread to be cut per revolution of the work piece.

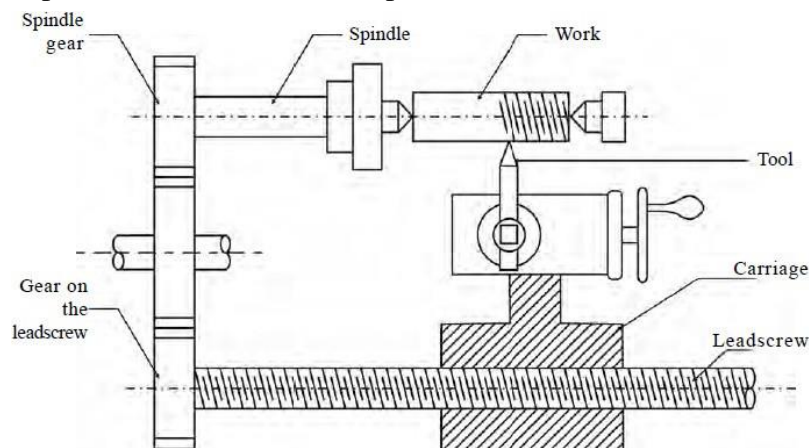

1.7 Tools used in a lathe

Tools used in a lathe are classified as follows

A. According to the construction, the lathe tools are classified into three types

1. Solid tool
2. Brazed tipped tool
3. Tool bit and tool holders

B. According to the operation to be performed, the cutting tools are classified as

1. Turning tool
2. Thread cutting tool
3. Facing tool
4. Forming tool
5. Parting tool
6. Grooving tool
7. Boring tool
8. Internal thread cutting tool
9. Knurling tool

C. According to the direction of feed movement, the following tools are used

1. Right hand tool
2. Left hand tool
3. Round nose tool

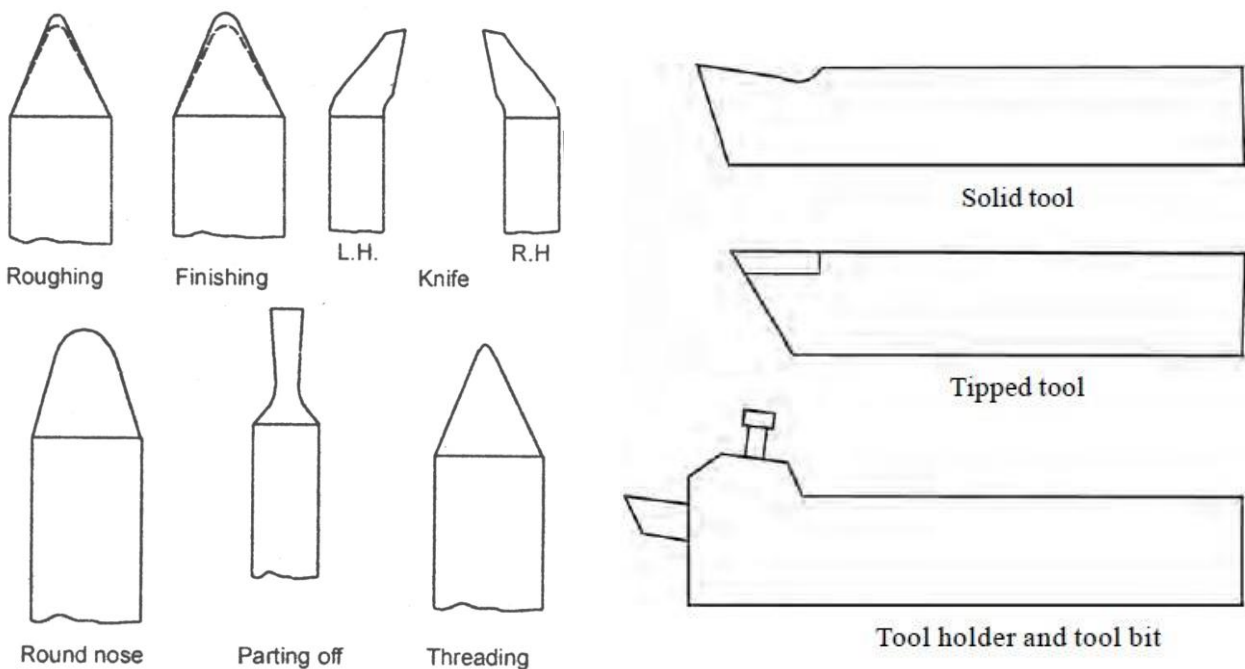
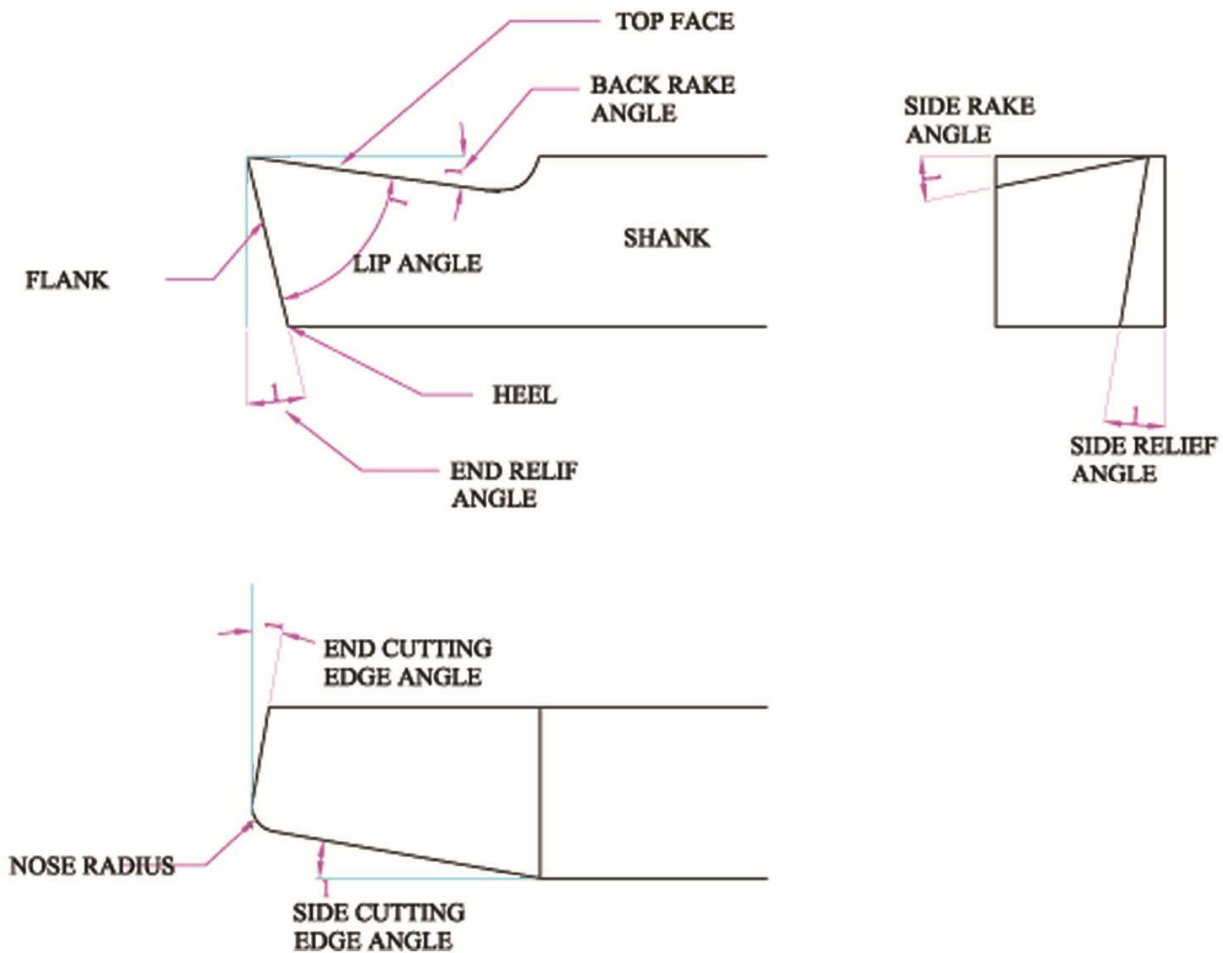

Fig : Types of tools

1.8 Cutting Tool Nomenclature

It means the systematic naming of the various parts and angles of a cutting tool.



1.9 Cutting tool signature

The signature is a sequence of numbers listing the various angles in degrees and the size of the nose radius in mm. This is a standardised numerical method of identification of a tool. The seven elements that comprise signature of a single point cutting tool are always stated in the order as follows:

1. Back rake angle (in degrees)
2. Side rake angle
3. End relief angle
4. Side relief angle
5. End cutting edge angle
6. Side cutting edge angle
7. Nose radius (in mm)

1.10 Cutting speed & Feed

Speed can be defined as the distance an object moves in a particular time.

The **cutting speed** of a tool is the speed at which the metal is removed by the tool from the workpiece. In a lathe, the cutting speed is the peripheral speed of the work past the cutting tool expressed in meters per minute.

$$\text{cutting speed} = \frac{\pi dn}{1000} \text{ m/min}$$

Where 'd' - is the diameter of the work in mm.

'n' - is the r.p.m. of the work.

Feed of a cutting tool in a lathe work is the distance that the tool advances for each revolution of the work. It is expressed in mm/revolution

Table showing cutting speed for various materials

Work material	Cutting tool material		
	High speed steel	Tungsten steel	Stellite
Mild steel	30 m/ min	80 m/ min	58 m/ min
High carbon steel	26 m/ min	65 m/ min	50 m/ min
Cast steel	15 m/ min	80 m/ min	42 m/ min
Cast iron	22 m/ min	80 m/ min	50 m/ min
Aluminium	90 m/ min	400 m/ min	330 m/ min
Brass	61 m/ min	200 m/ min	33 m/ min

Reference:

1. **Hajra Choudhary** Workshop technology Vol. II
2. **O.P.KHANNA, PRODUCTION TECHNOLOGY-II**